

Status of the LABM

G. Bonvicini, S. Di Carlo, WSU

Pedro Podesta, Samuel Izaguirre, UAS

Guillermo Munoz, Puebla

R. Ayad, Tabuk

Outline

- Introduction
- Yields calculations for Phase I
- Installation overview
- Electronics
- Optical Alignment

Beam-beam interaction limits the achievable luminosity and has many d.o.f. (7 in the transverse plane)

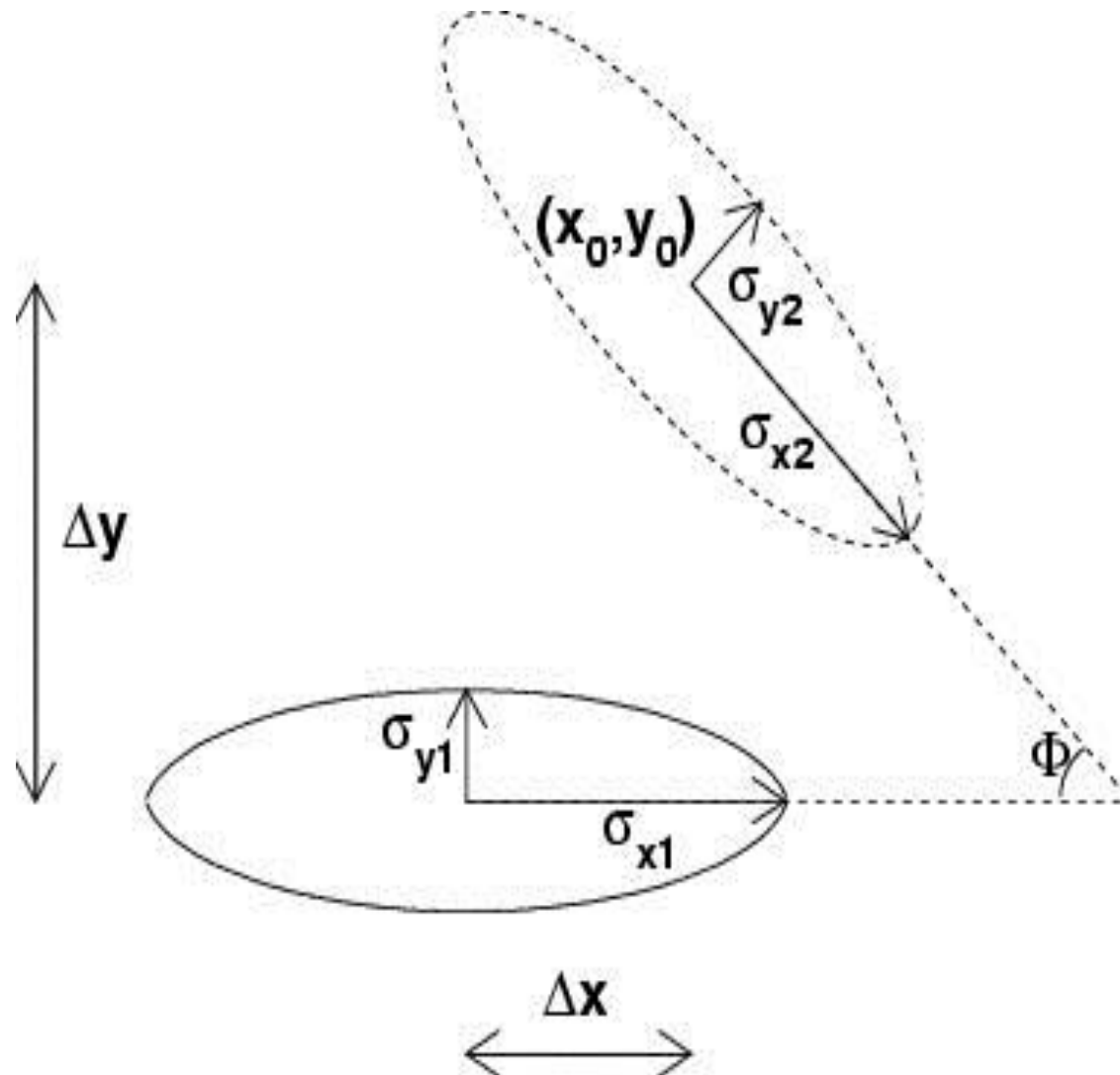

Some examples of Large Angle BMST pattern recognition (collinear beams case)

3 asymmetries are defined (4 are possible)

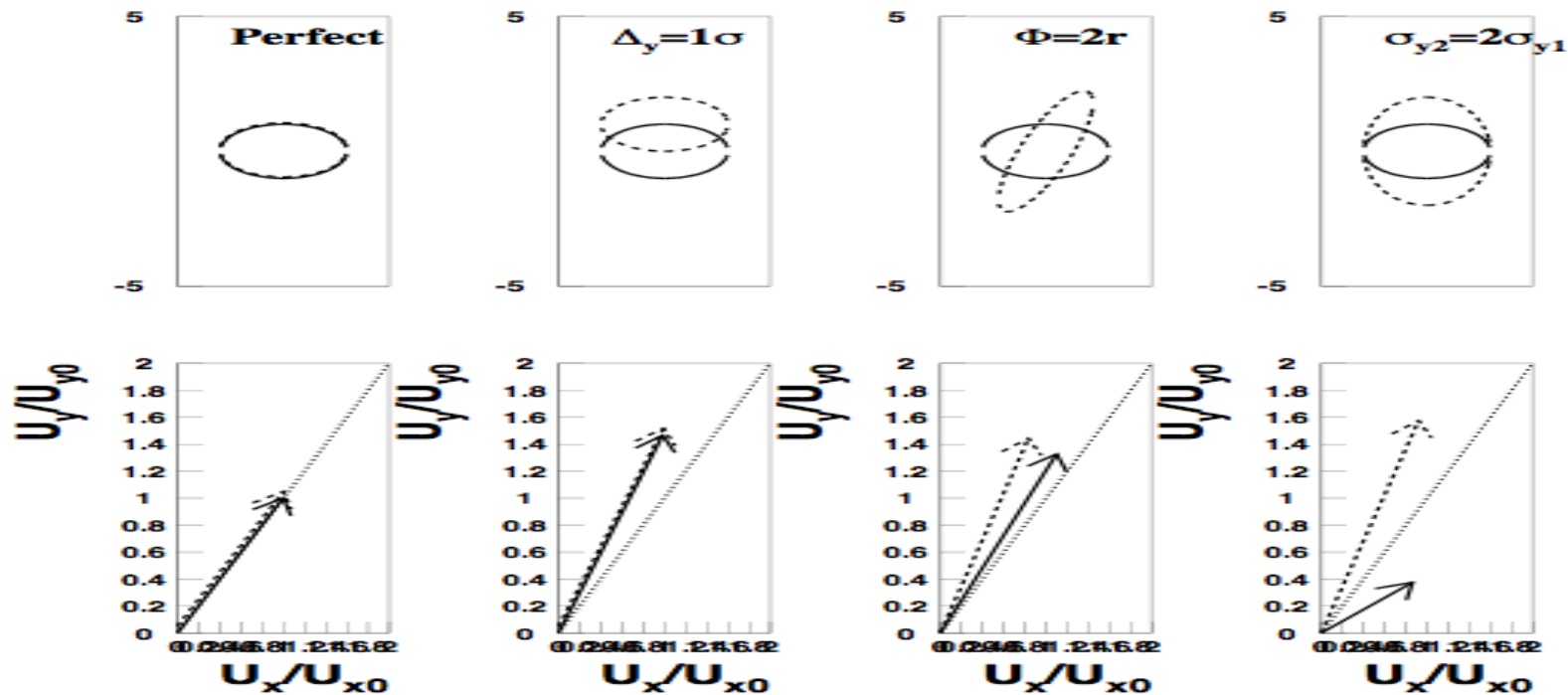

Calculations of Phase I yields completed (11 pages of paper written)

Remarks

Novel method to calculate such integrals

We are aiming at first observation of LA beamstrahlung during spring 2016

Expected photoelectrons yields of 22 and 27 kHz for HER and LER respectively

Sensitivity to beam asymmetries confirmed

σ_x	1mm	1mm
σ_y	6 μ m	6 μ m
σ_z	6mm	6mm
I(A)	1.3	1.8
f	125 MHz	125 MHz
Yield	31kHz	22kHz

Beam pipe insert

- View port location at ± 90 degrees minimizes backgrounds, polarization measurement errors, and provides redundancy against beam orbit errors
- Mirrors are $2 \times 2.8 \text{ mm}^2$, Be
- Located at 3850 mm (LER) and 4900 (HER) from IP ($9.9 < q < 10.4 \text{ mrad}$ for LER, $7.8 < q < 8.2 \text{ mrad}$ for HER)

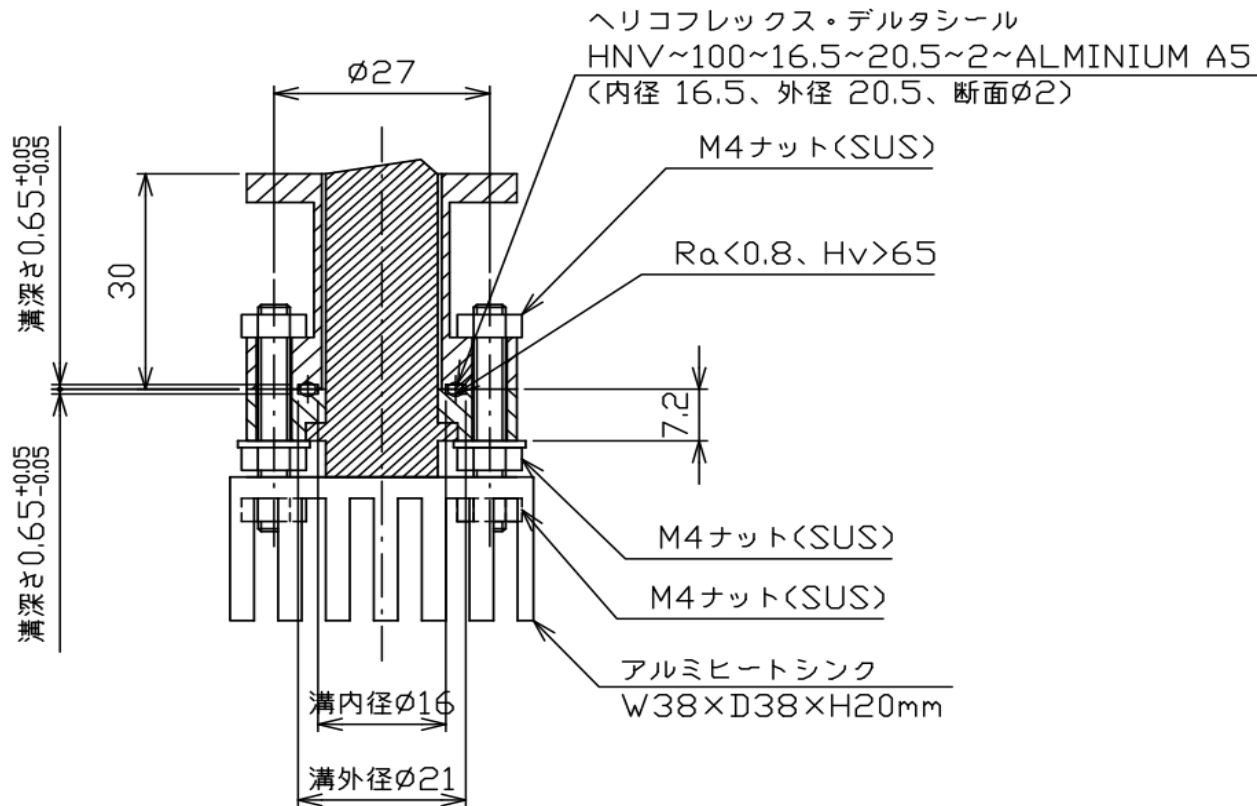

Viewport 1

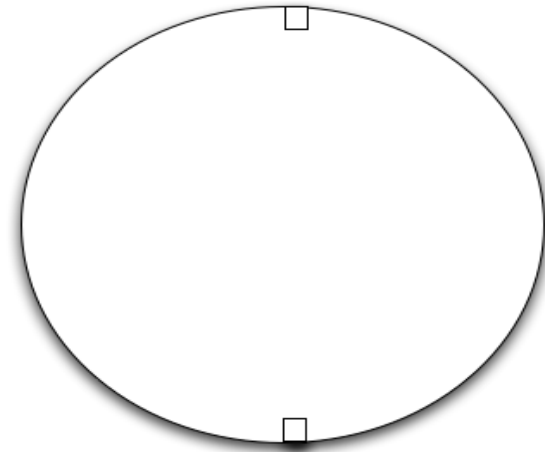

Viewport 2

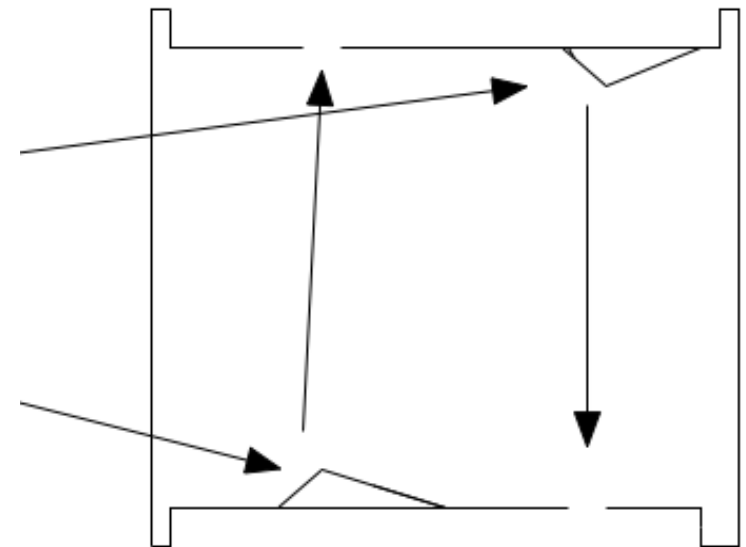

Optical channel NIKKO side (I)



Optical Channel NIKKO side (II)



Half Optics Box

HIGHLIGHTS

- Wollaston prism
- Ruled gratings
- Light collectors
- PMTs (Bialkali, $350 < \lambda < 650 \text{nm}$)
- Allows wavelength change by changing only gratings pitch

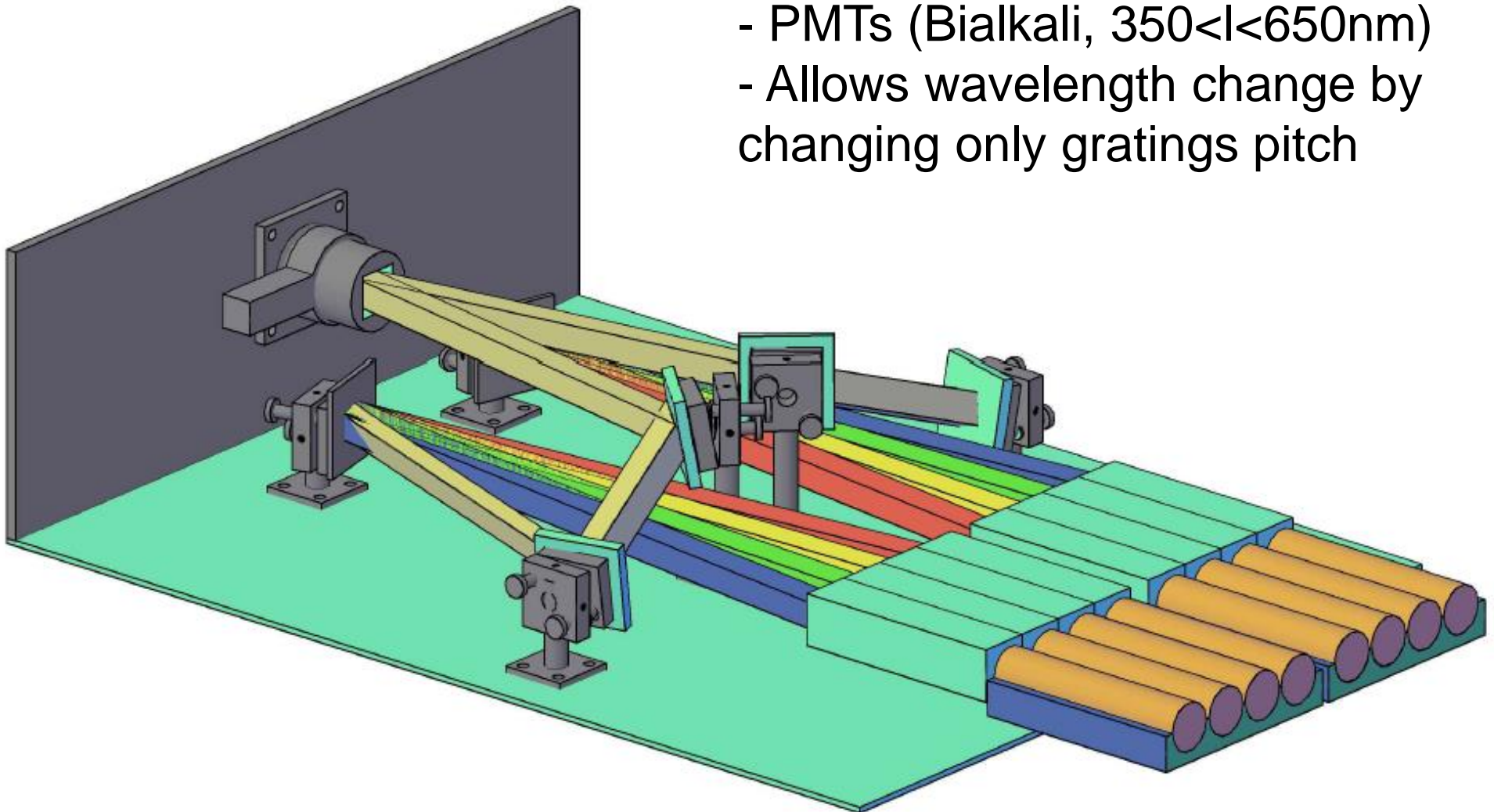

Electronic

S

- | LABM Data description
- | Electronics card
- | Scaler Calibration
- | Slow control
- | DAQ

LABM Data scheme

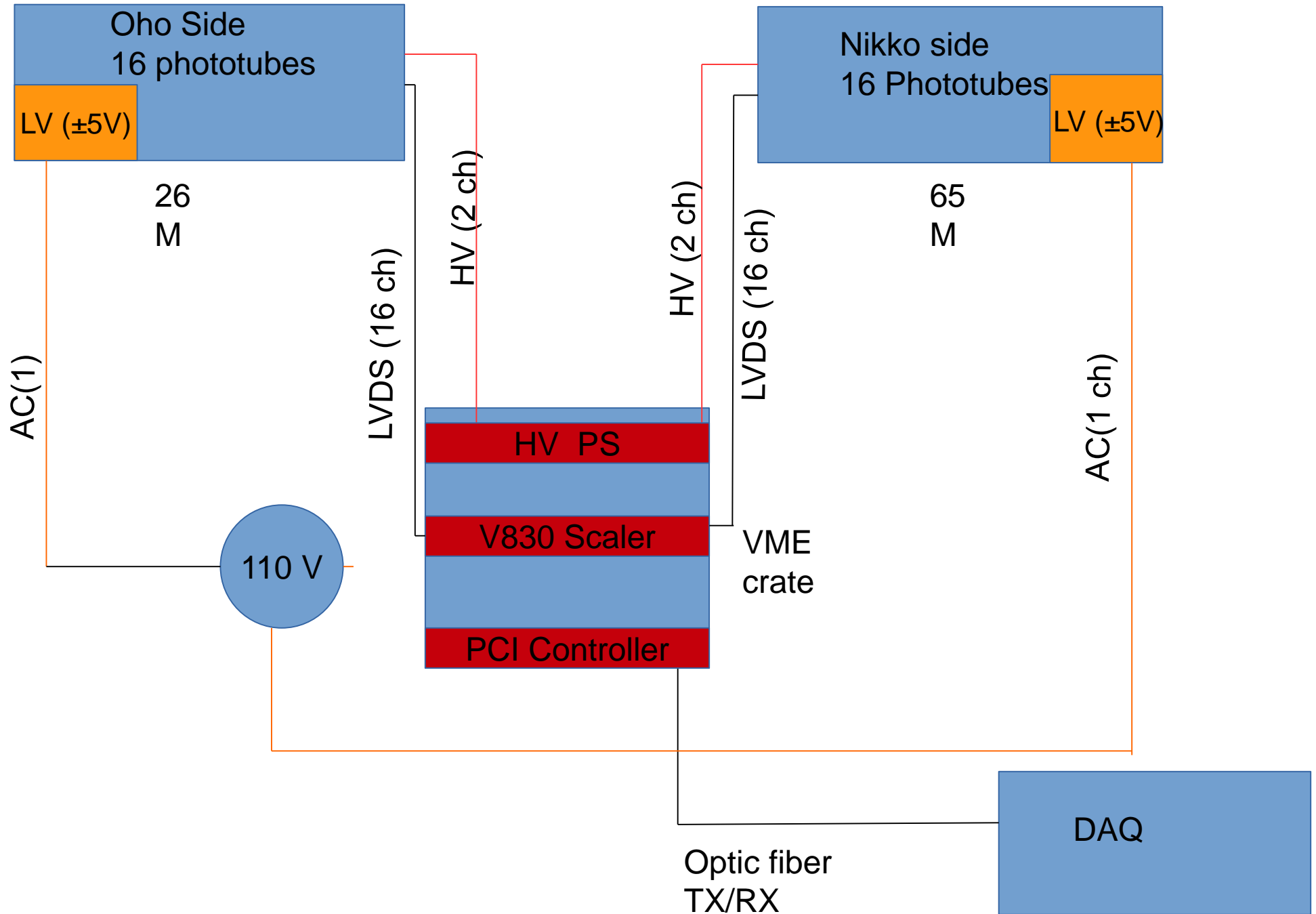

Electronics Cards: Guillermo Tejeda

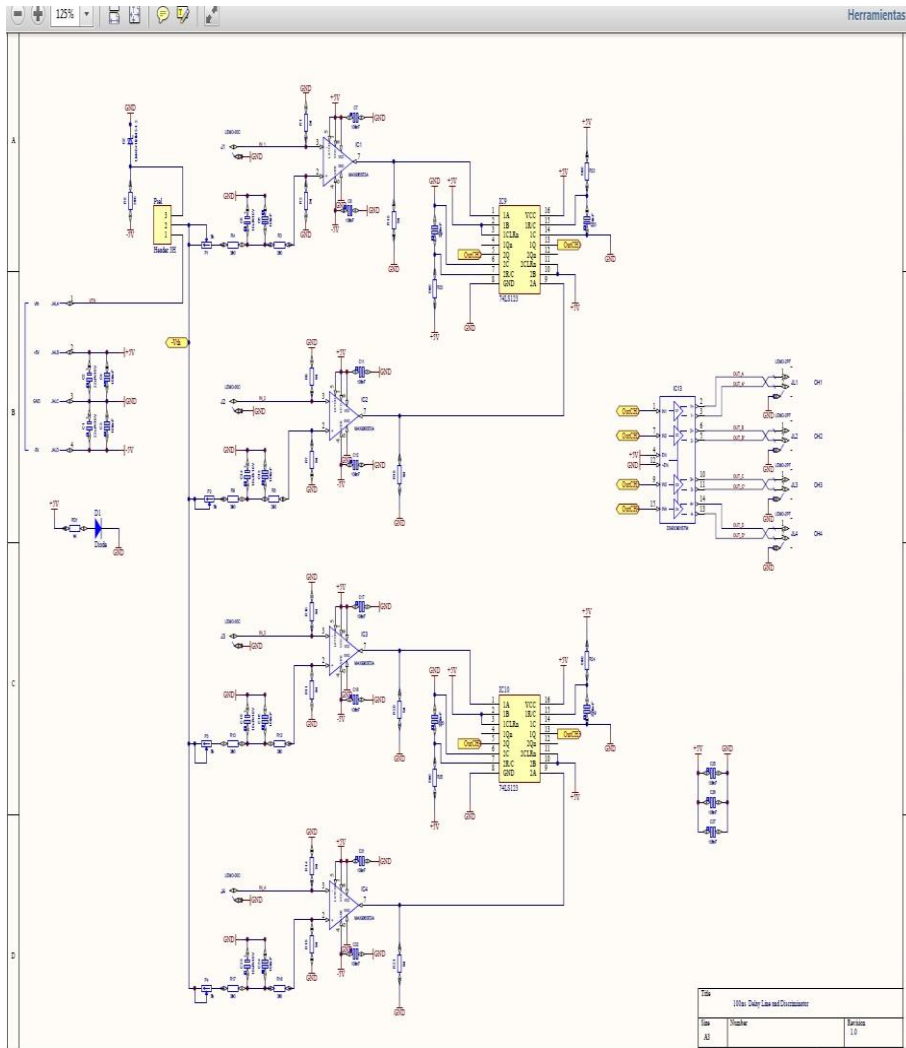

Electronic Card

Oho Side
16 phototubes

Phototube signal is digitized two eight channels cards per box

Phototube connection

Discriminator 10 mV

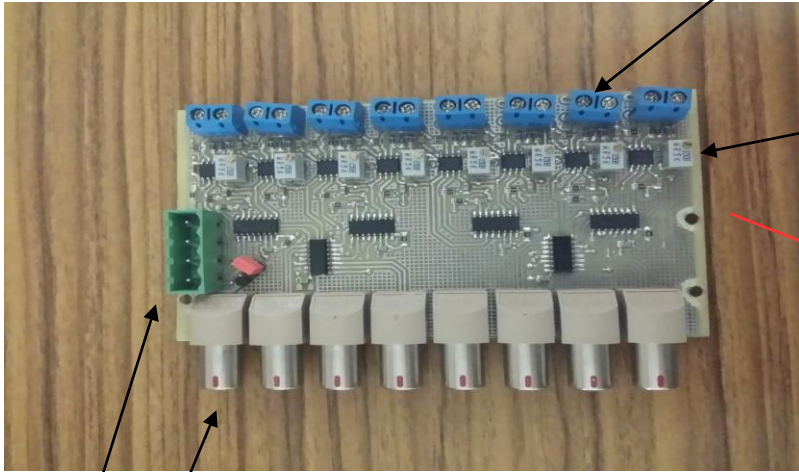

Connectors
SuperLemo

LV power +/- 5V

In total 4 cards, two spares

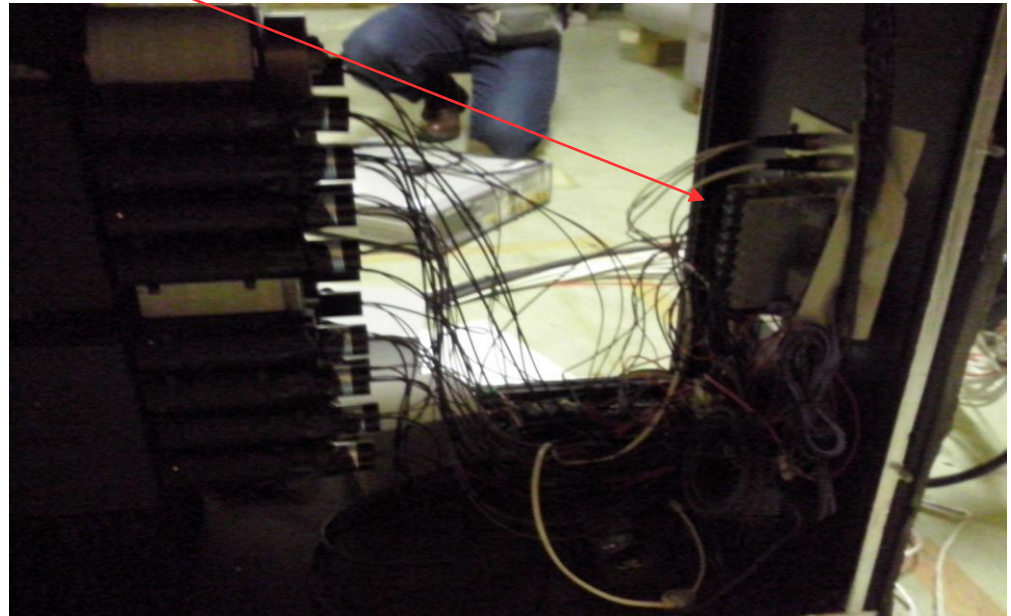

Patch panel

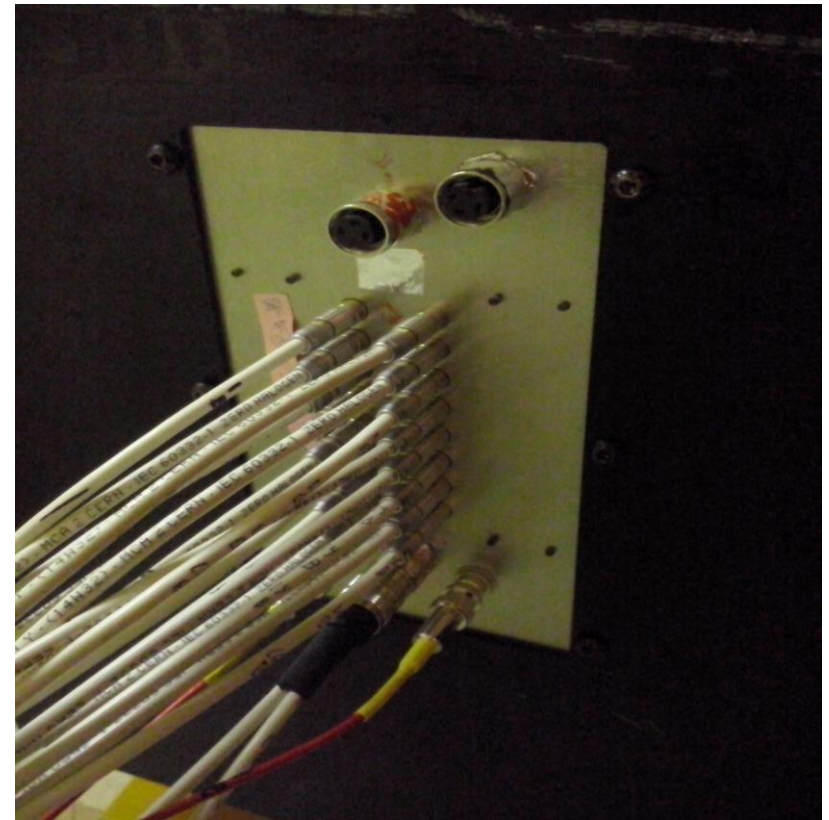
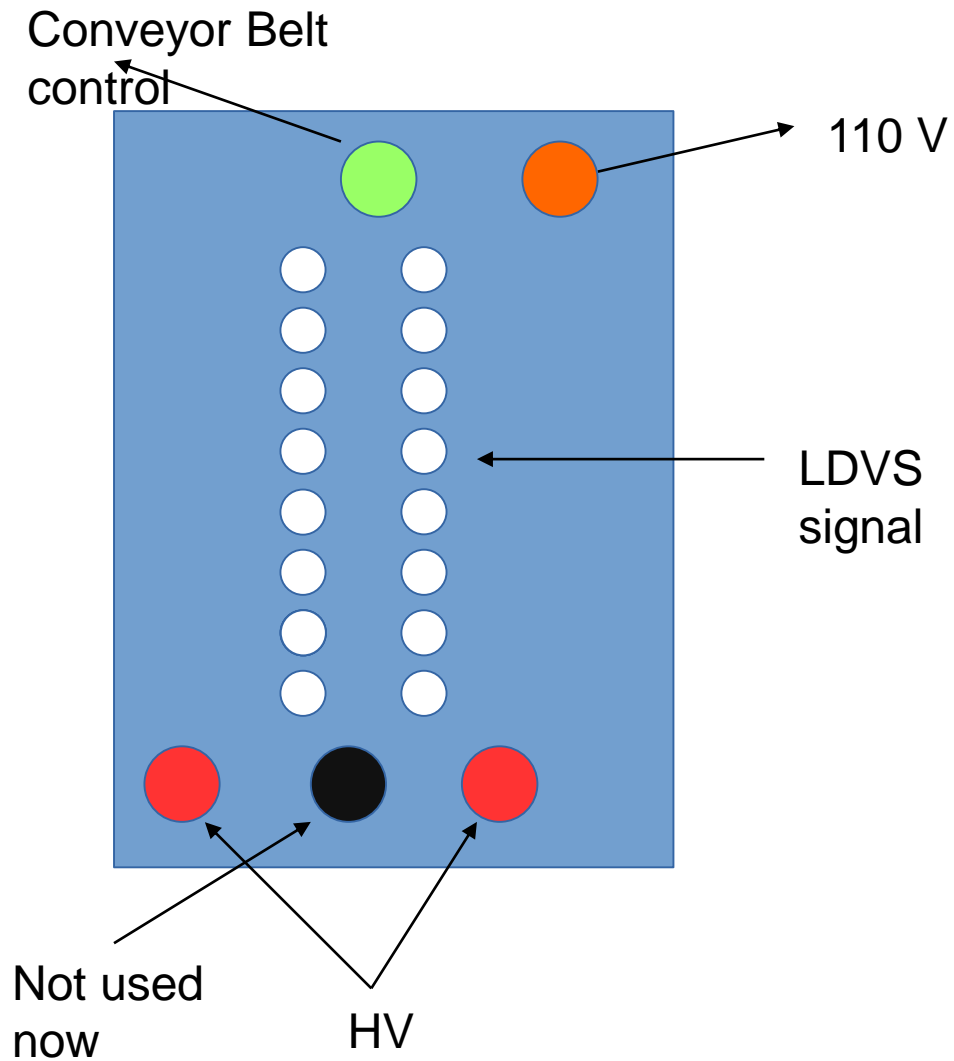

Patch panel was electrical isolated in order to prevent noise

VME for data acquisition and HV

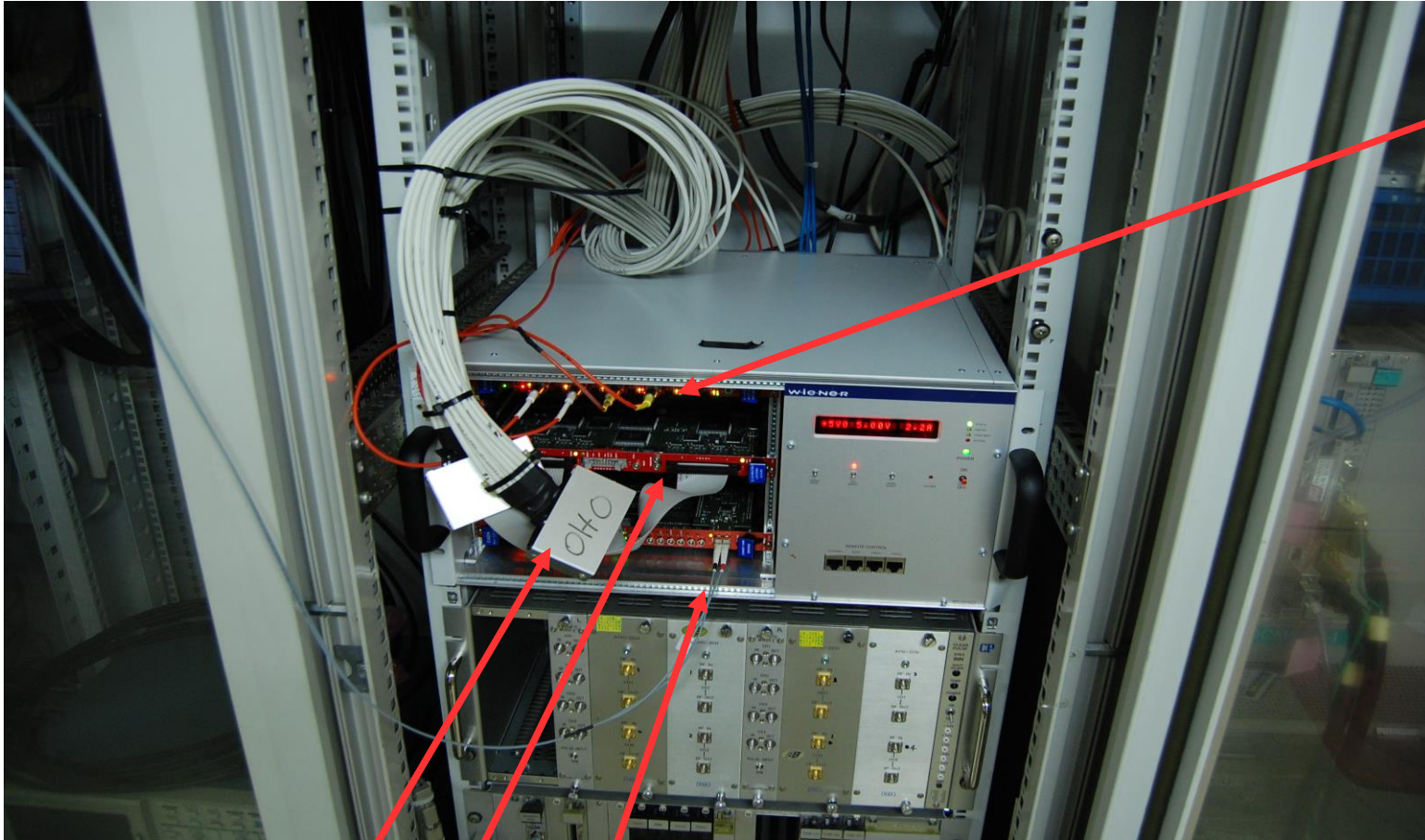

HV
CAEN V6533
Six channels
4 being used

CAEN V2718 controller, optic fiber. A3818 pci adapter

V830 CAEN Scaler 32 channels ribbon connector

Adapter from 16 cable to ribbon 100 Ohm termination

Calibration I

LVDS Signal as output of the card



PMT signal

Output Signal

LVDS Signal after traveling by cable and connectors.

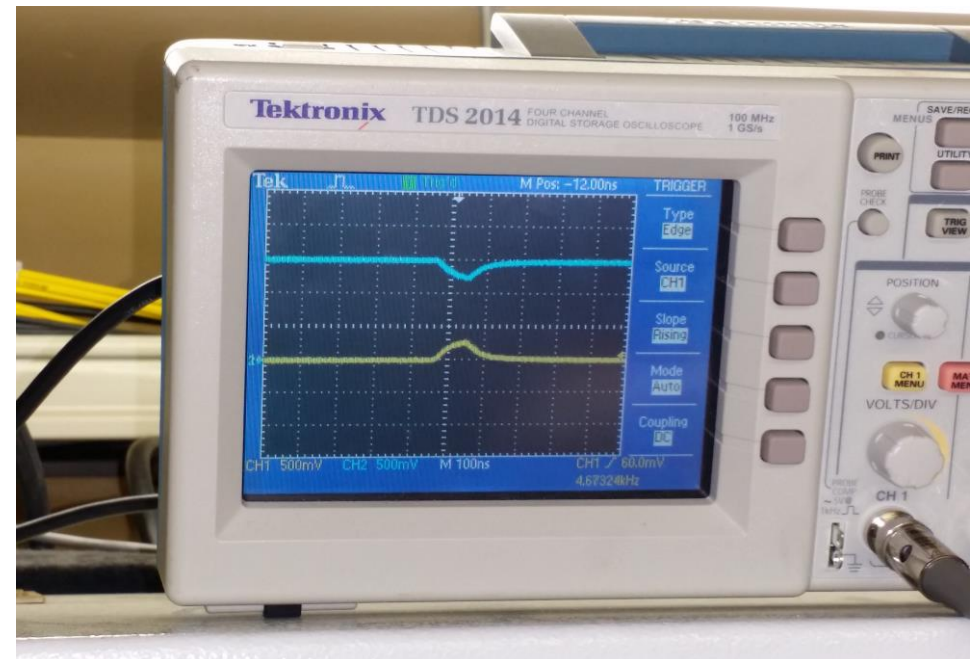

Calibration II

Use a wave generator to simulate the rates : Thank John Flannagan

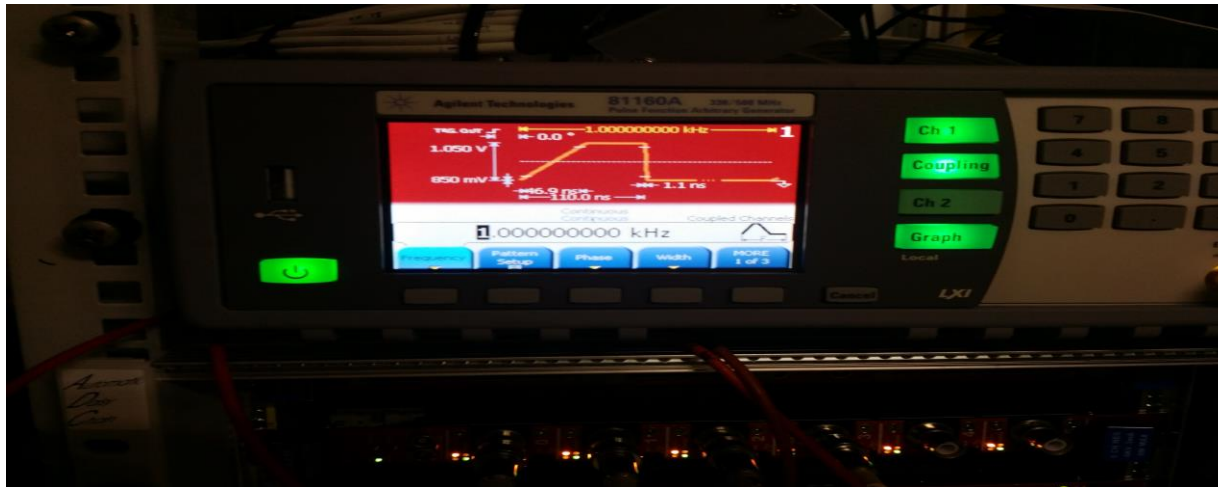

- Width 110ns
- Lead Edge 46.9ns
- Trail Edge 1.1ns
- Amplitude 1.05V
- Low 850mV
- Lead Impedance 110ohm

Calibration III

We found we can work up to 5.0 MHz

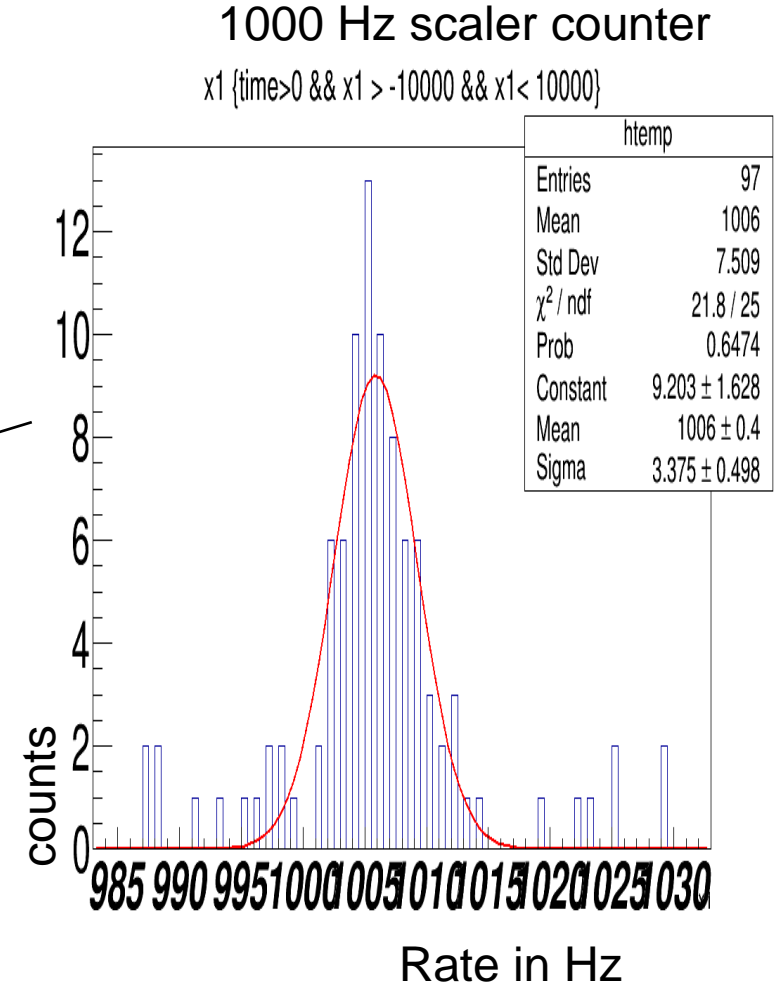
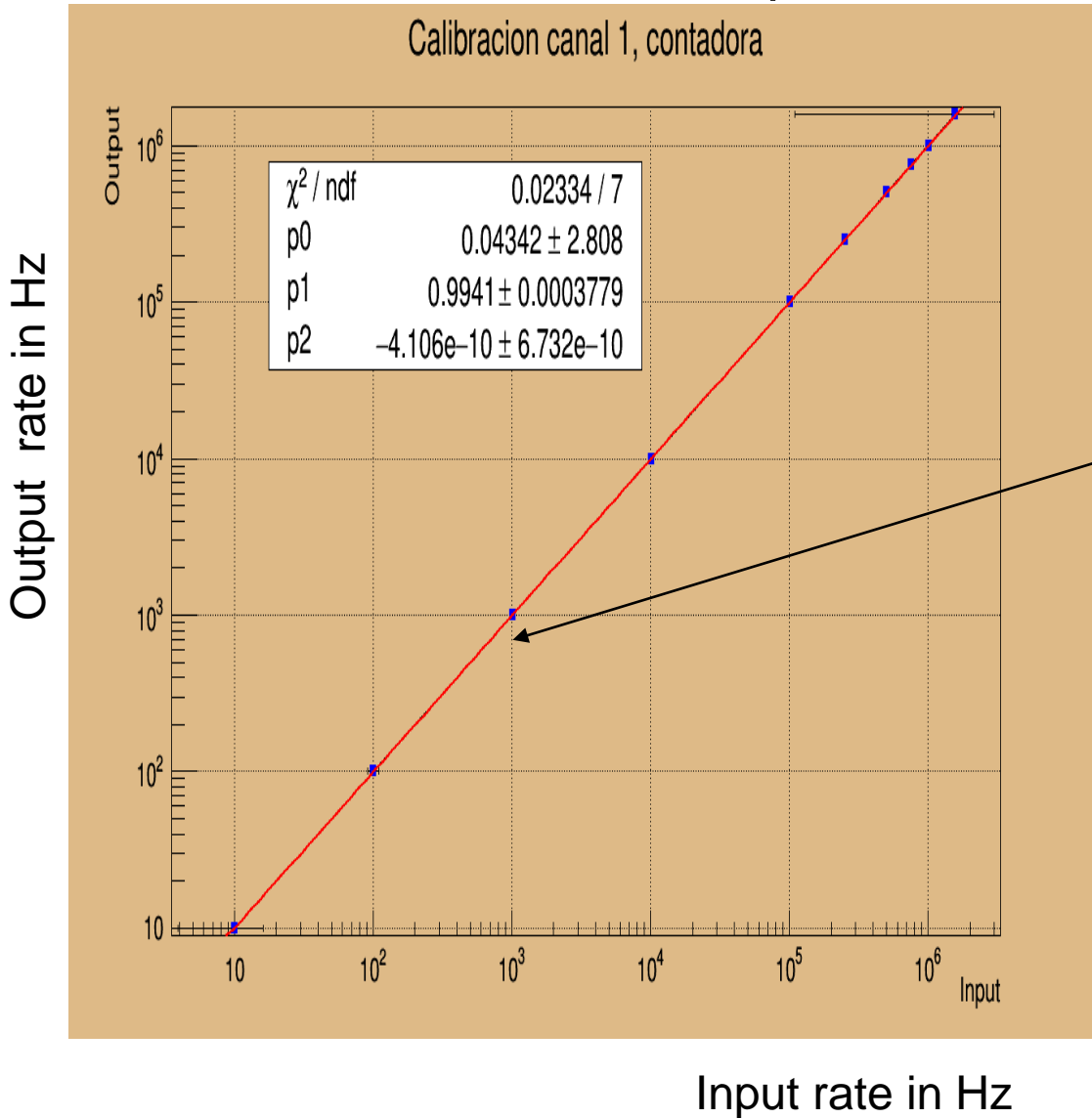

We found one problematic channel, the spare is here , we need to test it.

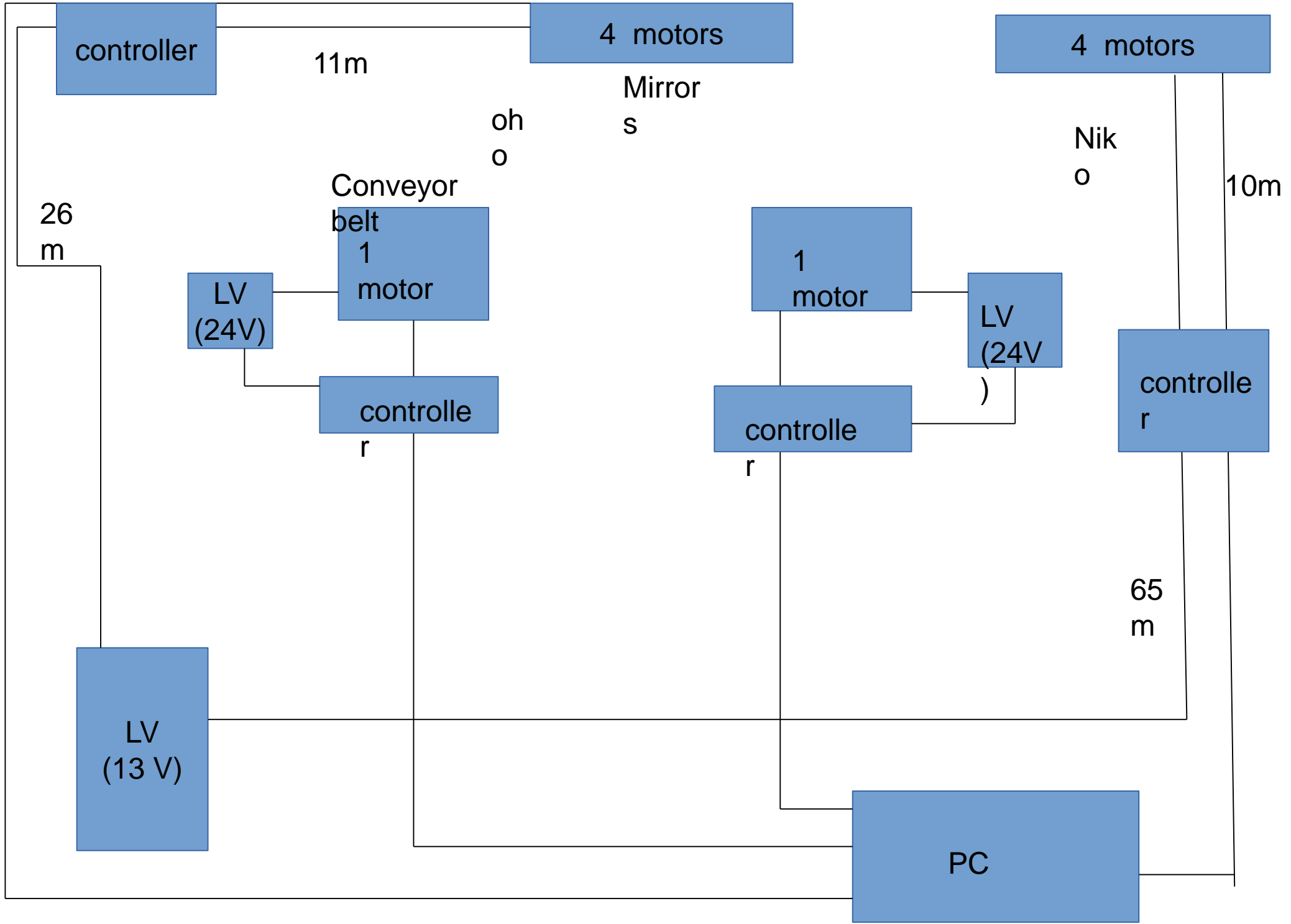

SLOW CONTROL

Slow control

Mirror Control

- All drivers for mirror are controlled by the single usb port, just change base address
- The routines for controlling the mirror and found the maximum are ready but have not been tested in full

Conveyor Control

- Each drivers are controlled by one usb port, the routines for moving the conveyor belt are programmed directly in the motor driver
- Already done and working

Primary mirror control

Primary mirror

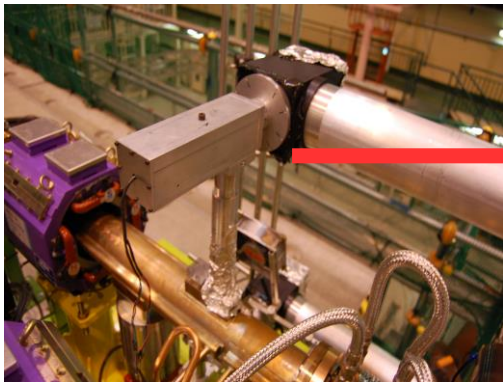

2 motors per mirror

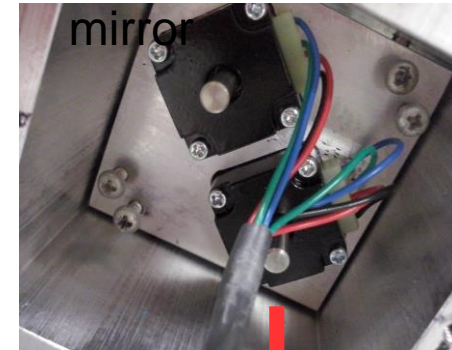

Driver box

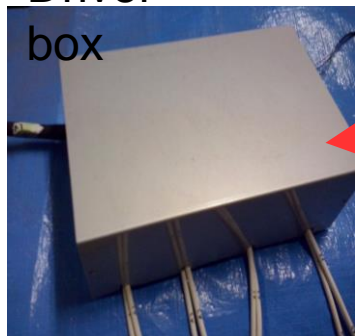

Labm optic box

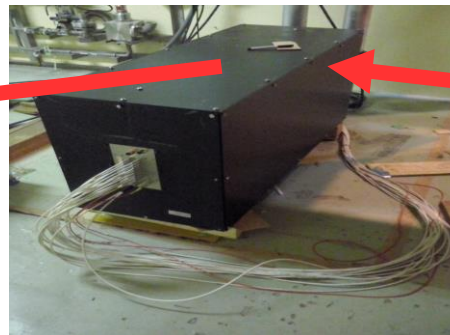

connectors

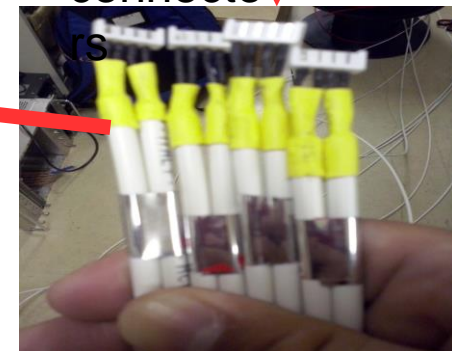

10 m

Motor Drivers



LV 13.8 V



3 m

PC Control

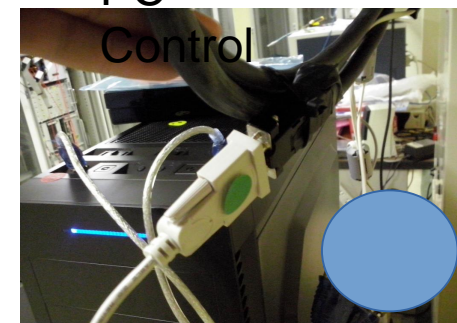

Conveyor belt control

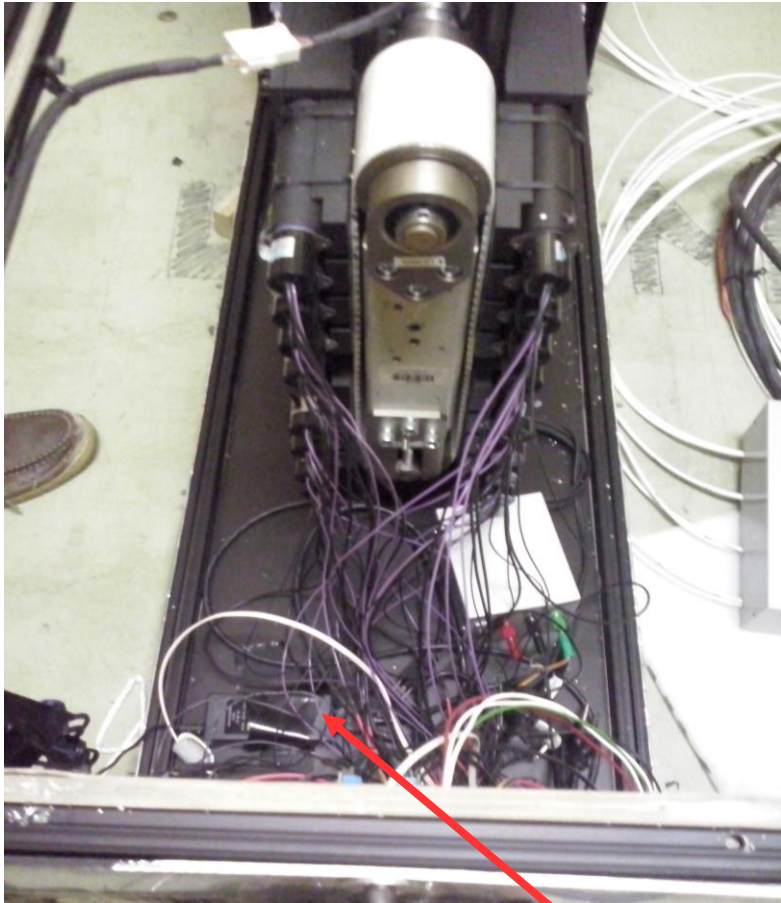

Controller and 24 V power supply
Both need 110 V

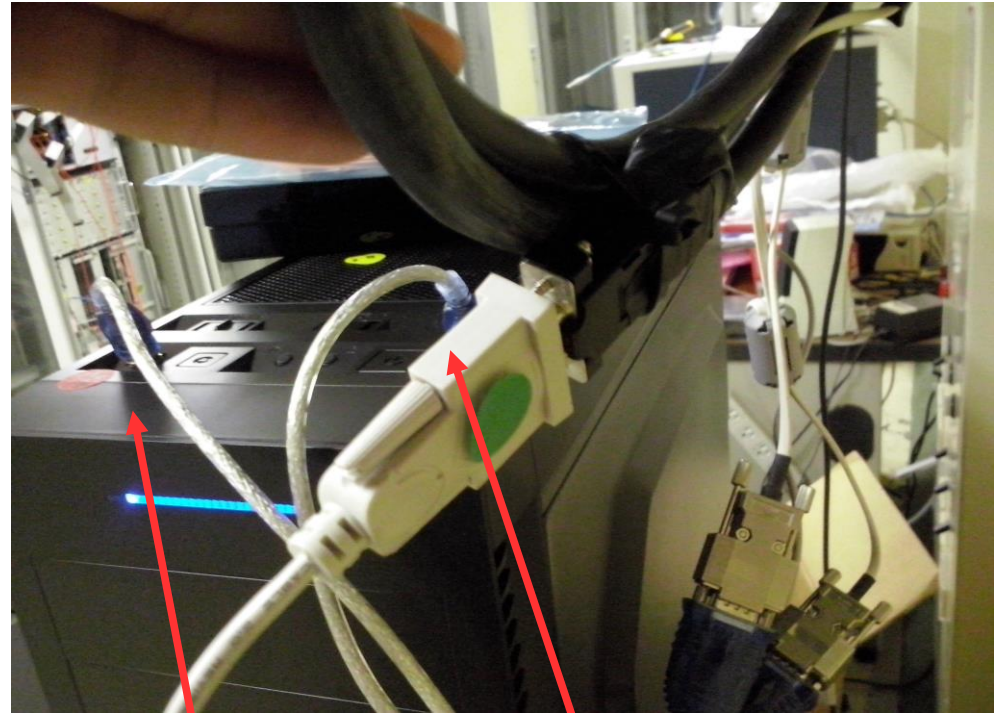

Oho

Nikko

DAQ

- The Scaler is read using c++ program and CAEN libraries
- The data is recorded as ASCII file 32 columns
- The Monitoring is done using ROOT

HV

- HV is controlled using CAENGECCO

Run 589 for 63 hour finished on August 7- 9 9:15

Nikko rates

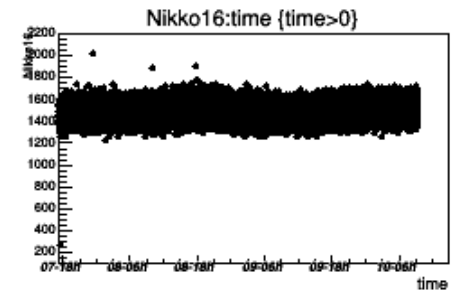
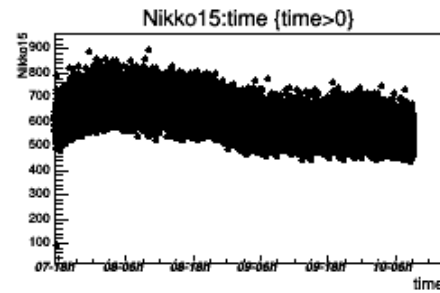
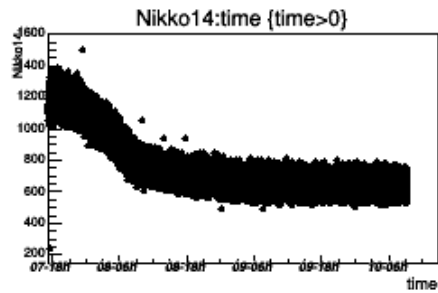
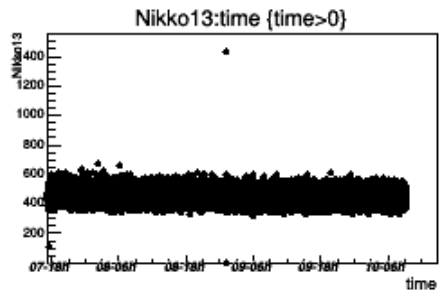
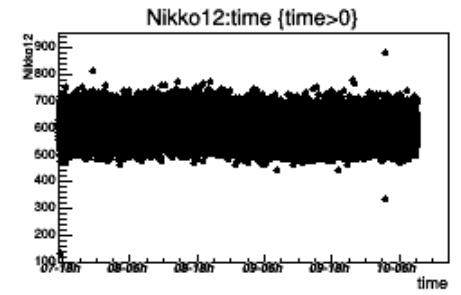
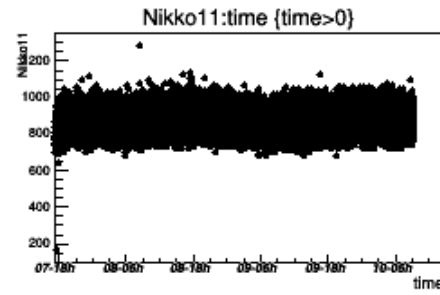
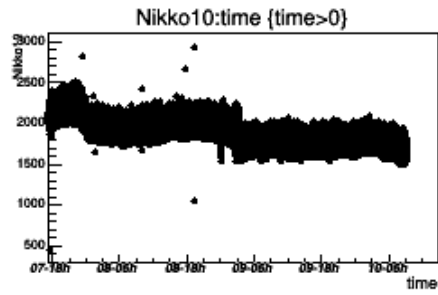
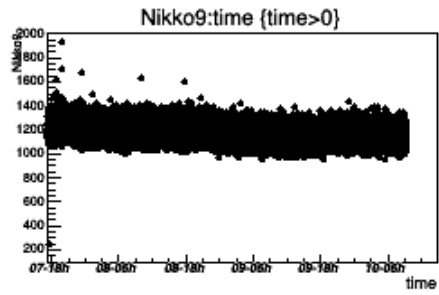
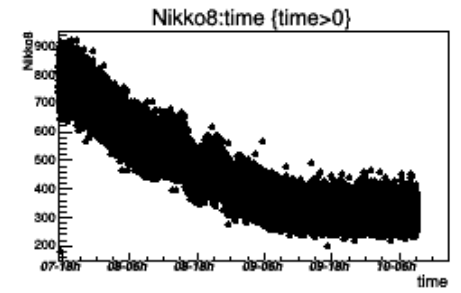
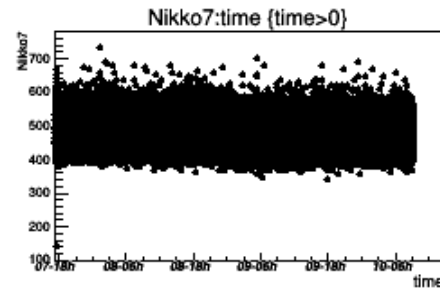
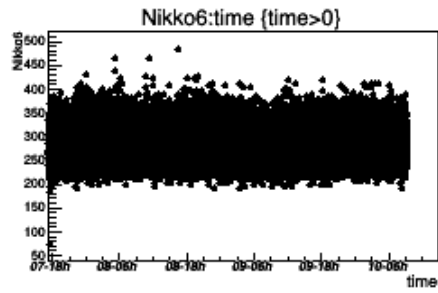
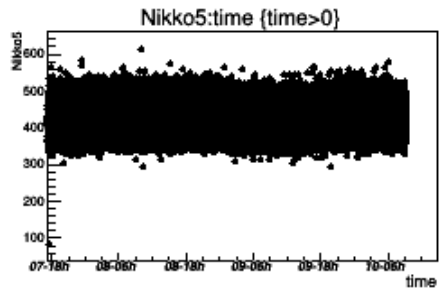
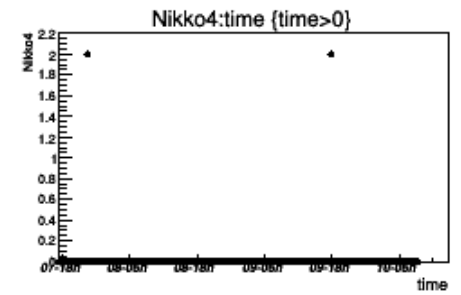
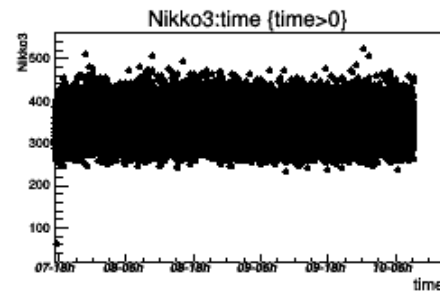
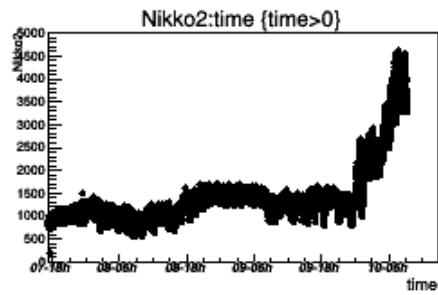
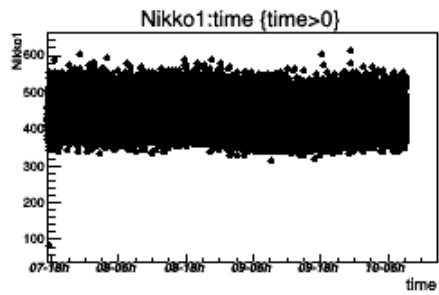

Oho rates run 589

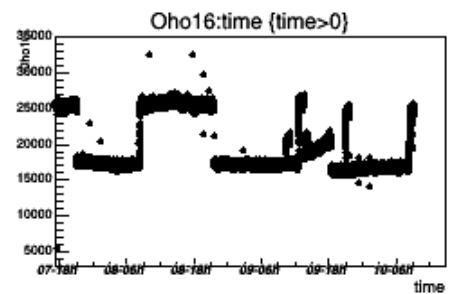
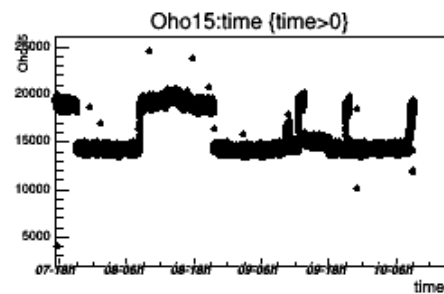
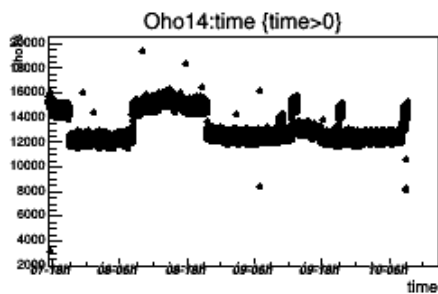
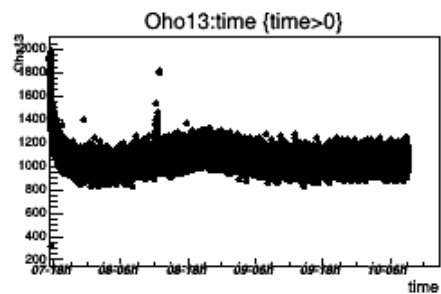
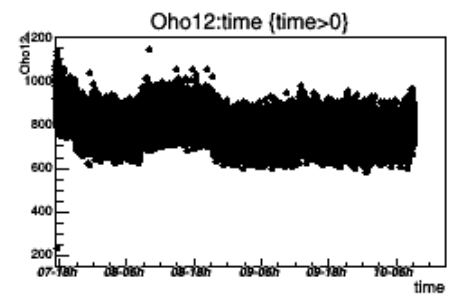
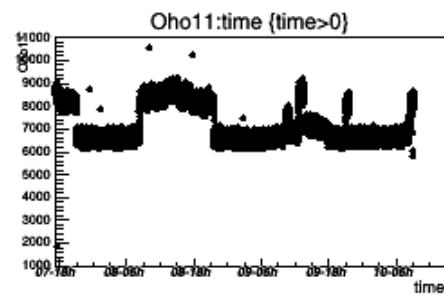
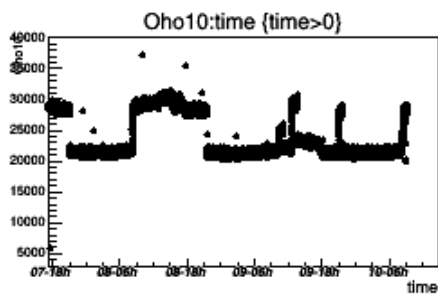
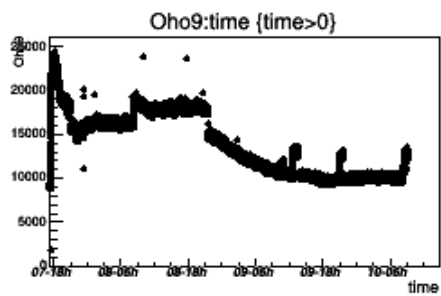
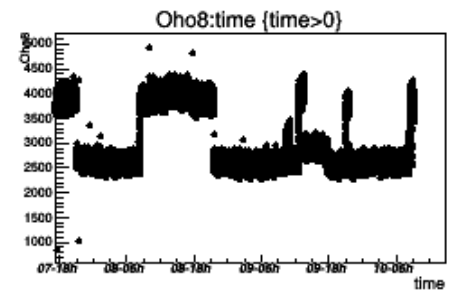
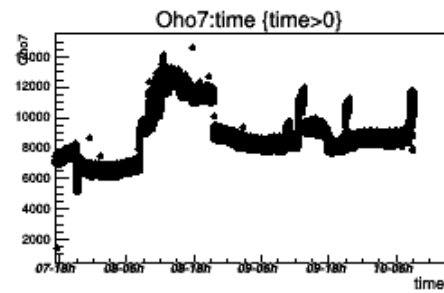
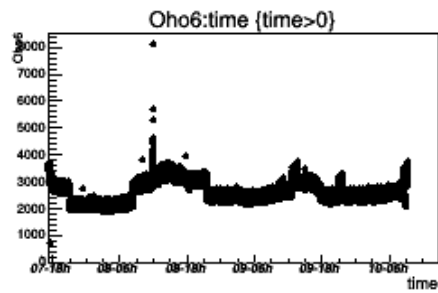
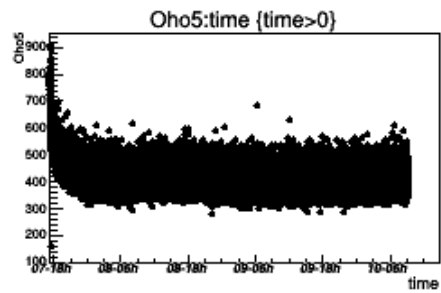
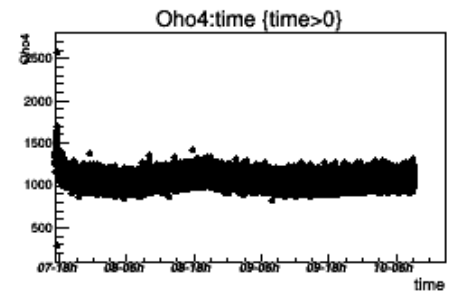
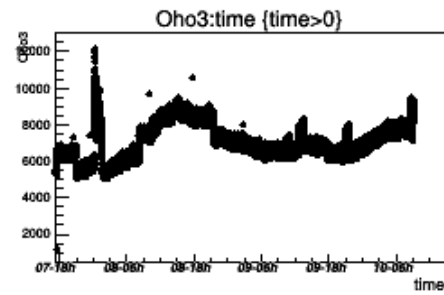
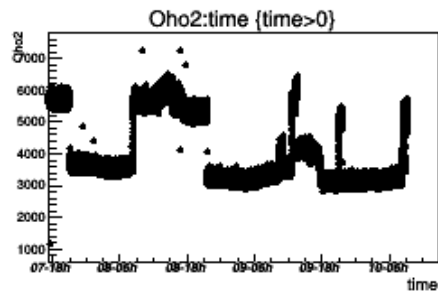
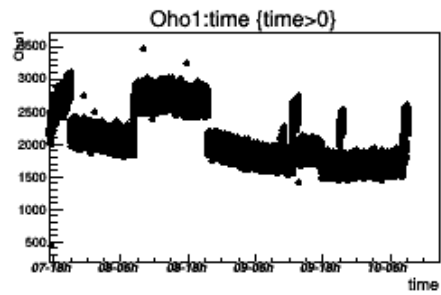

Optical channels alignment for LABM

Salvatore Di Carlo WSU

Outline

- Optical channels
- Elbows alignment
- Box alignment

Drawing of the 4 optical channels

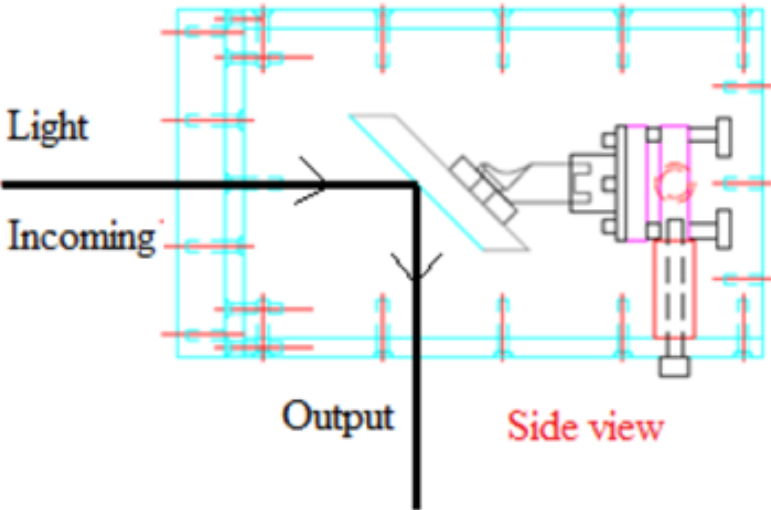
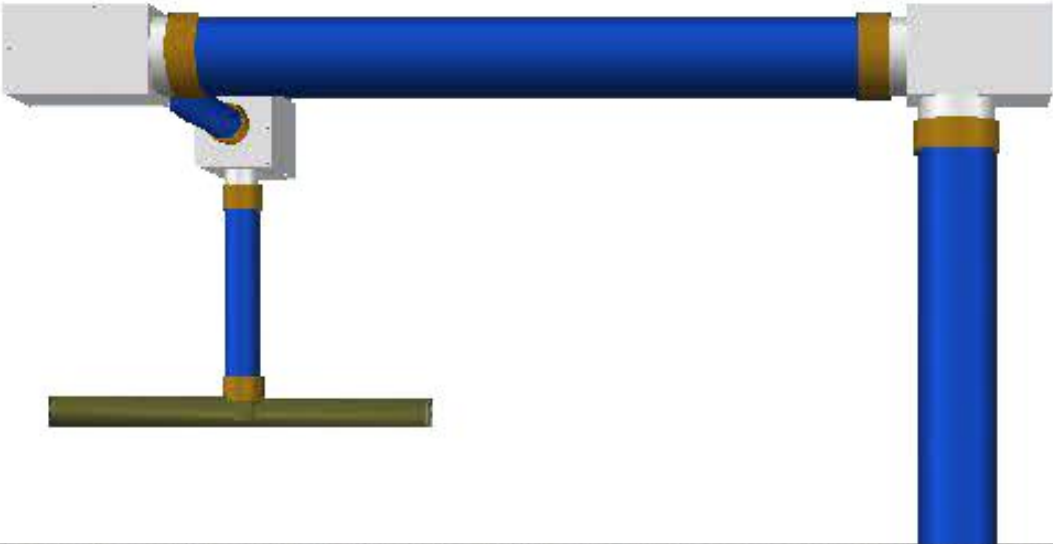

CONCRETE LAYER



Details of the elbows

Elbow

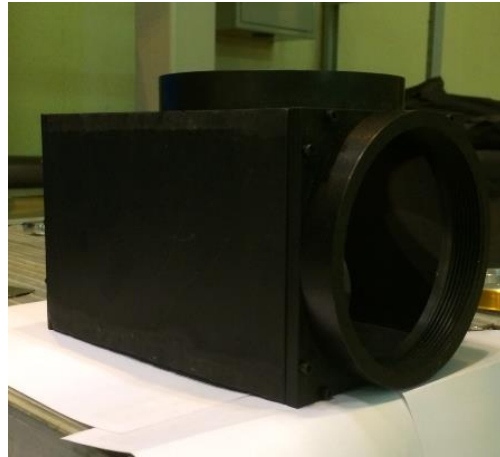

Front view

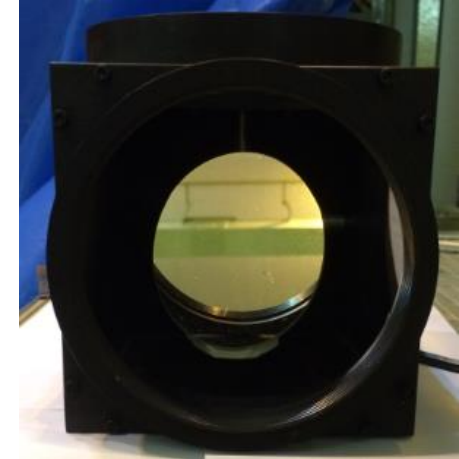

Back view

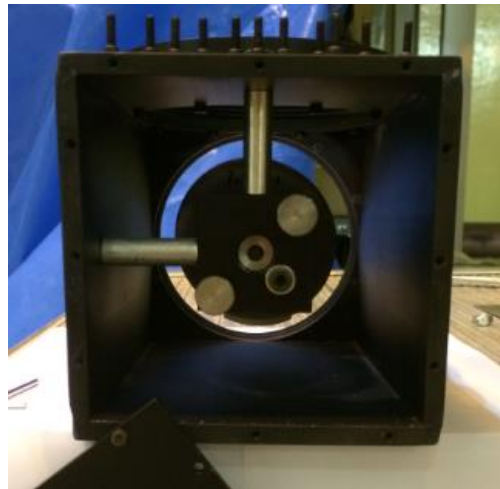

Without mirror

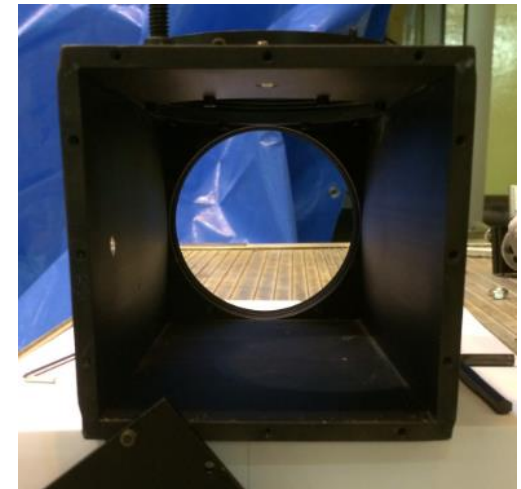

Elbows alignment procedure

Side view

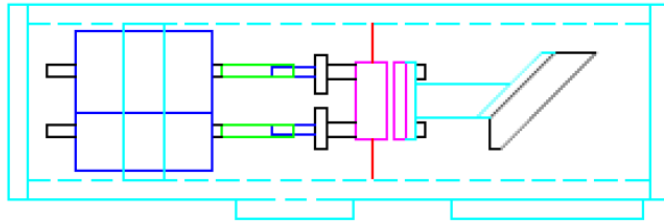

Remotely controlled primary mirror

Elbow with removed mirror



Side view

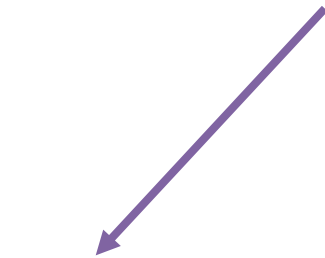
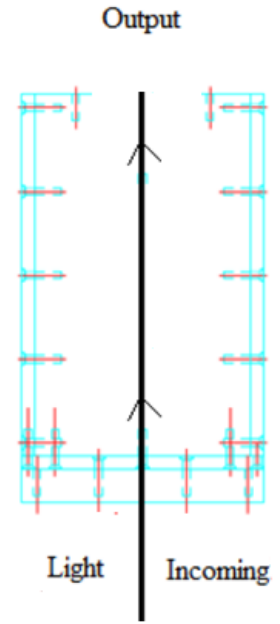

Elbow whose mirror needs to be aligned

Side view

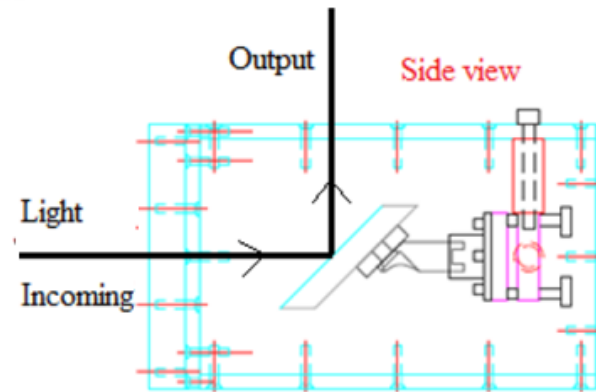

Window for light source



Box alignment 1

Laser source
parallel to the pipe

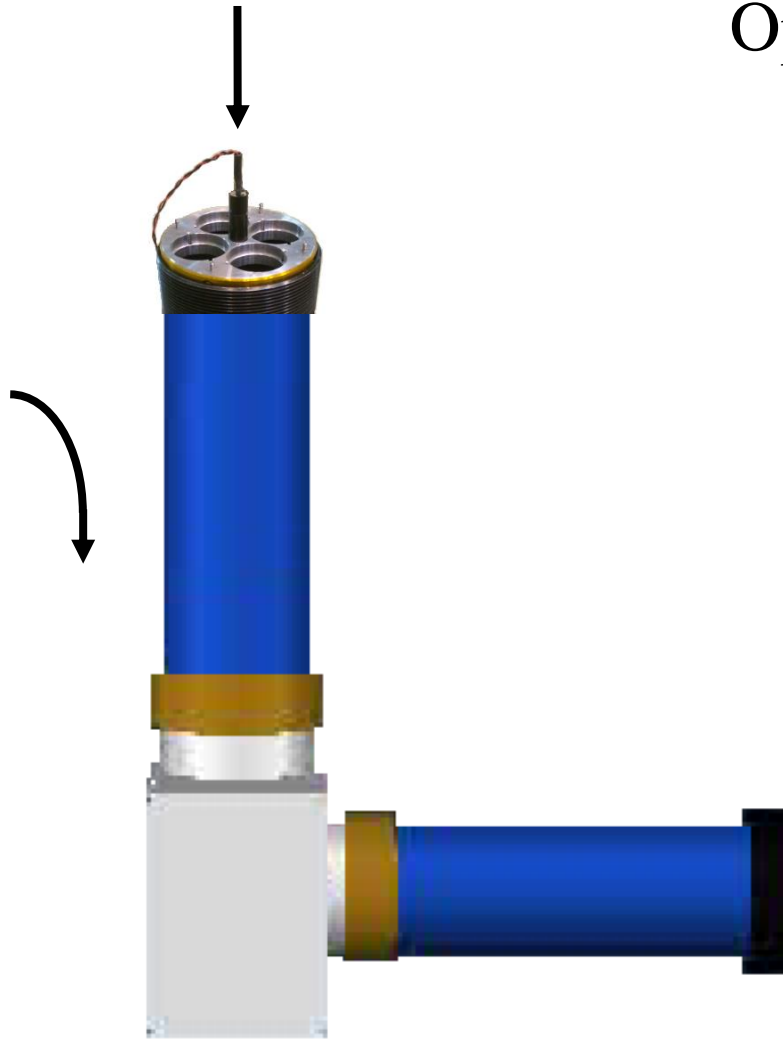

Optical components
to align

Photomultiplier



Box alignment 2

Lasers of different colors



SET A: ORIZONTAL POLARIZATION
SET B: VERTICAL POLARIZATION
WAVELENGTH RANGE: 350-650 nm

Optical components to align

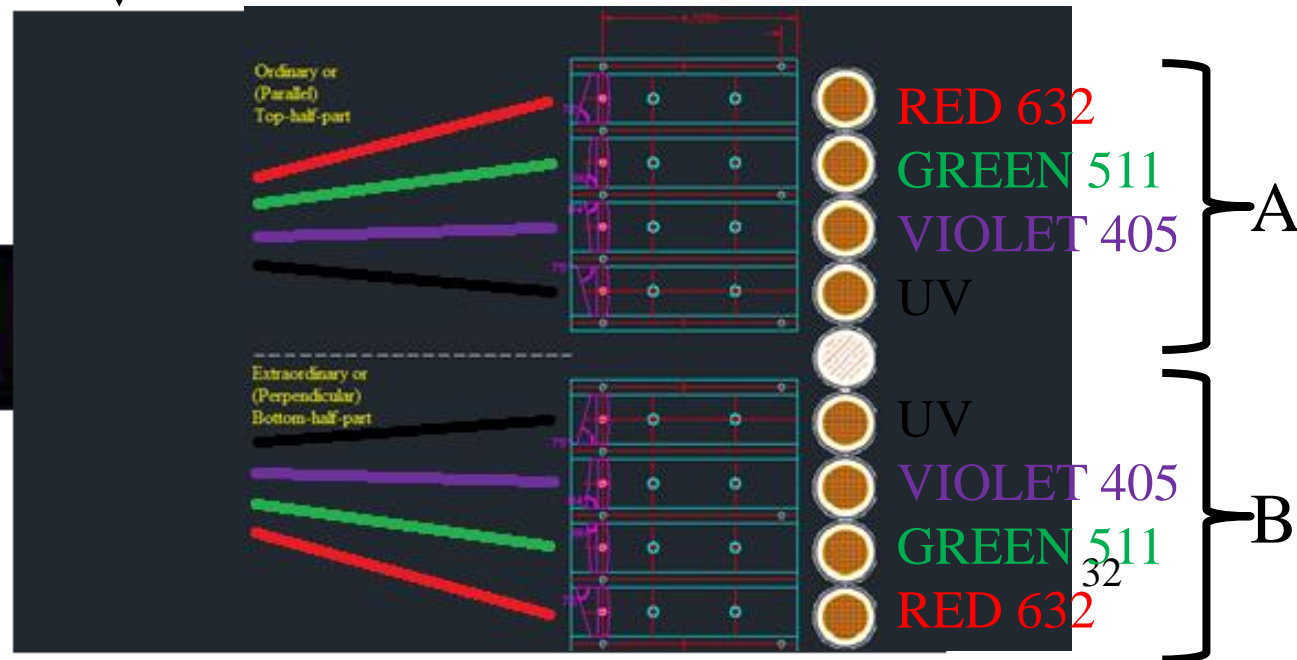

Conclusions

- **We had 2 days access Aug. 6 and 7. Aug. 6** spent reinstalling the Oho device and alignment (it takes 1.5 hours to disassemble both sides, 16 hours to assemble and align both sides)
- We took Oho-side data with attenuated laser light placed on an emitter directly above(below) the Beam Pipe vacuum window. 13 runs of 12 conveyor belt rotations each.
- Numerous mistakes the first time, most notably we allowed a lot of ambient light. Also lots of traffic in the area that day, so the shadows changed the ambient light.
- Data fit for pedestals, view port fluxes, relative PMT efficiencies, 47 parameters total (31 fit parameters after pedestals are extracted by an independent method). 124 significant measurements per run.

Relative efficiency results (Oho side, first try) – measured to 1.5 -4% - PMT rotation calibration appears to work (results on our Twiki page)

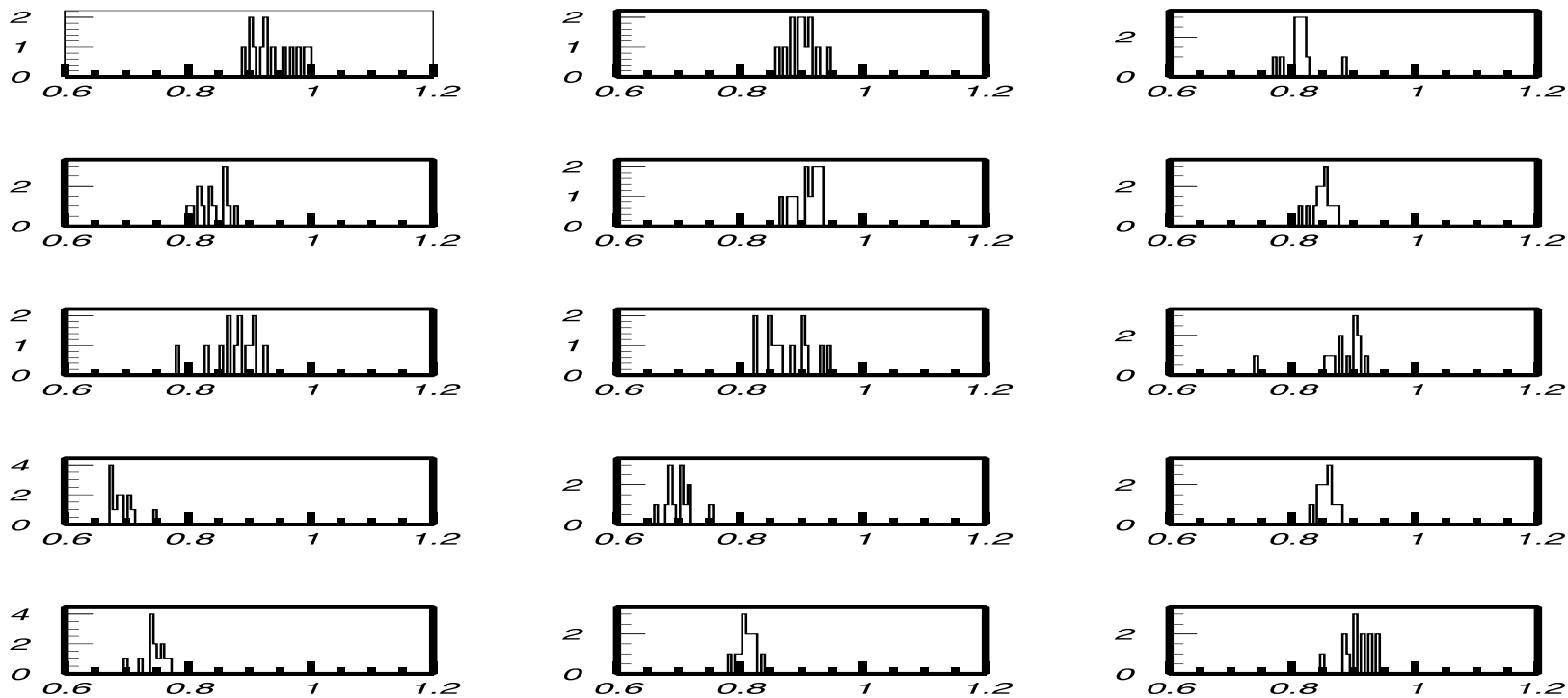

Plans and schedule I

- Calibrate the spare VME 830 card
(Beginning of September 2015)
- Test the mirror and code
(October 2015)
- Improve the DAQ and monitoring
(September 2015 ongoing)
- Improve the HV monitoring
(October 2015 ongoing)
- Test EPICS

Plans and schedule II

- Numerous parts (spacers, dark covers and light blockers, new set of remotely controlled mirrors, Box supports, more better collimator for alignment and data taking) built and installed. Reinstall detector in late October. (October 2015)
- Take data with well covered calibration holes, polarized data, filter data, hot lamp data, laser data to characterize the detector response (October 2015)
- SuperKEKB note on LABM performance to be completed after calibration data. We strive for 1% relative calibration of device (September 2015)
- Publish calculation paper